

This sight flow indicator is ideal for you to visually check the flow, presence, colour and condition of a liquid, gas or condensate.

- ◆ High quality robust design
- ◆ Pressures up to 16 bar
- ◆ Temperatures up to 200°C
- ◆ Short lead times
- ◆ Designed and manufactured in the UK.



## Application

The Vista 'Ball' is a single sided stainless steel indicator that can be used on pipe sizes from 8mm to 40mm ( $\frac{1}{4}$ " to  $1\frac{1}{2}$ "). The white PTFE ball rises when flow starts and is clearly visible from distances. The indicator must be installed horizontally with the glass dome positioned upwards.

Applications include:

- Showing the presence of condensate in steam return lines
- Indicating chemical dosing on water treatment plant
- Ensuring that flow of cooling water is maintained to specialised equipment
- Detecting changes in colour and condition of liquids during processing

## Construction

The bodies are cast in high quality 316 stainless steel.

The glass window is held in place by a stainless steel clamp ring and sealed with a Viton O'Ring, giving superior protection.

The sight glasses can be supplied with screwed connections to NPT, BSP parallel or taper.

## Quality

All Flowpoints indicators are manufactured to the highest standards.

The quality system is independently audited by BSI and certified to ISO 9001.

Full material traceability is maintained, material certificates and pressure test certificates are supplied on request.

## Materials of Construction

Body - Stainless steel ASTM 351 CF8M

Clamp Ring - Stainless steel BS 3100 302 C25 (304 C15)

Ball - PTFE

Glass Dome - Annealed Borosilicate

O'ring - Viton

Gasket - Klingersil C4400

Fasteners - Stainless steel

## Flow Requirements

Size (mm)	Minimum Flow (l/min)	Out of Socket (l/min)	Pressure Drop – 2 m / sec (bar)
8	0.3	1.5	0.1
10	0.3	1.5	0.1
15	0.3	1.5	0.1
20	2.5	5.0	0.2
25	4.0	8.0	0.2
32	11.0	23.0	0.3
40	11.0	23.0	0.3

## Dimensions and Weights

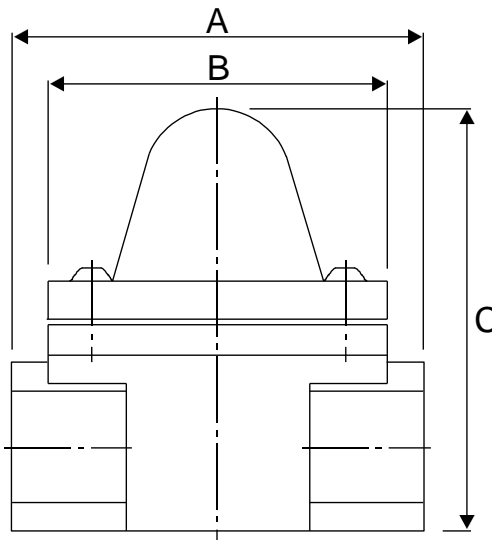

Bore Size mm (inch)	Weight (kg)	Overall Length 'A' (mm)	Width (Clamp) 'B' (mm)	Overall Height 'C' (mm)
8 (1/4)	0.72	76	60	81
10 (3/8)	0.70	76	60	81
15 (1/2)	0.65	76	60	81
20 (3/4)	1.35	89	60	100
25 (1)	1.25	89	60	100
32 (1.1/4)	2.70	118	73	126
40 (1.1/2)	2.50	118	70	126