

### PARTS & MATERIAL LIST

No.	ITEM	MATERIAL
1	GLAND ASSY	VITON & P.T.F.E.
2	SIGHT TUBE	ANNEALED BOROSILICATE HEAT RESISTING GLASS / POLYCARBONATE PLASTIC
3	GUARD TUBE	POLYCARBONATE PLASTIC / ST.STL. / ALUMINIUM
4	END UNIT	BRASS / ST.STL. / G.M. / POLYPROPYLENE PLASTIC
5	INTERMEDIATE SUPPORT	BRASS / ST.STL. / G.M. / POLYPROPYLENE PLASTIC

### CONNECTION OPTIONS

TOP CONNECTIONS	BOTTOM CONNECTIONS
1/2" BSP.PL. / NPT	
3/4" BSP.PL. / NPT *	
ANSI / DIN FLANGE *	
WELD OR SCREWED TANK BOSS *	

\*THESE OPTIONS ARE AVAILABLE FITTED WITH A.S.V. (AUTO SHUT OFF VALVE) THE ASV FEATURE MEANS THAT IN THE UNLIKELY EVENT THAT THE GLASS IS DAMAGED, THE CONTENTS OF THE TANK WILL NOT BE LOST.

### TECHNICAL DATA:

Max. working pressure for Glass Sight Tube: up to 22 Bar.g. & 15°C @ 400mm centres \*\*

Max. working pressure for Polycarbonate Sight Tube: up to 14 Bar.g. & 100°C.

Intermediate supports are used to reduce the length of the glass column sections and so achieve higher pressures & temperatures.

Max. Gauge Centres: To suit requirements.

Min. Gauge centres: 150mm

For gauges longer than 1000mm, the column is split into sections using intermediate supports. Each sections maximum length is 1000mm.

### FLANGE CONNECTION:

Suitable flanges can be fitted in place of male thread connections, as per 'Connection Options' table.

Welded or screw type tank boss' available for thread connections.

Flange pattern's from 3/4" or 20mm upwards can be supplied.

## CONNECTION OPTIONS

(WELDED TANK BOSS, SEE SHEET 1, MAIN GAUGE VIEW)

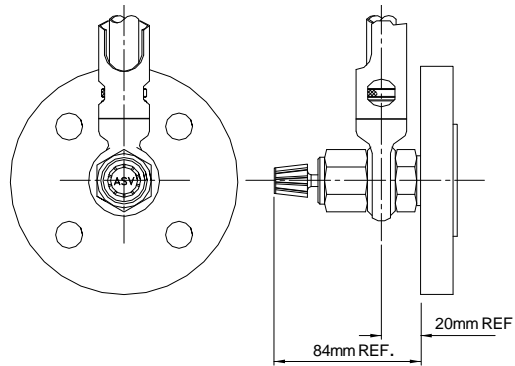

FLANGED OPTION

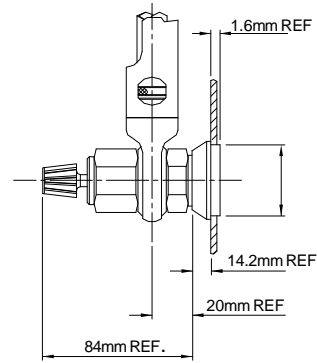

WELDED TANK BOSS OPTION

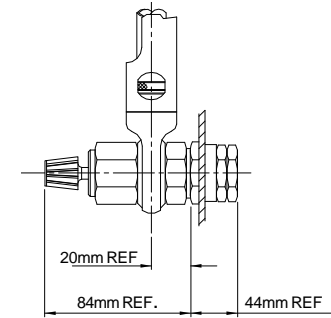

NON WELD TANK BOSS OPTION

## GAUGE END OPTIONS

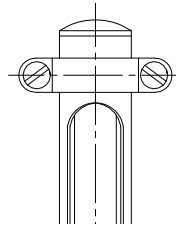

OPENCIRCUIT

The Quickmount gauge can be supplied with no valve at the top connection. This is suitable for non-pressurised tanks only.

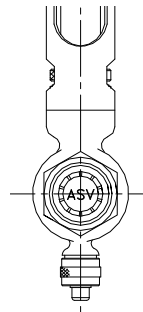

DRAIN/VENT VALVES

Drain and vent valves are available on request.

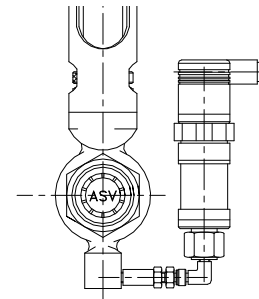

PRESSURE TRANSMITTER/  
ELECTRONIC READOUT

The Quickmount gauge is available with a pressure transmitter (normal output of 4-20mA) to enable electronic readout, digital display or computer interface.

## MODEL G22 WITH TUBULAR SIGHT GLASS

### GLASS SIGHT TUBE

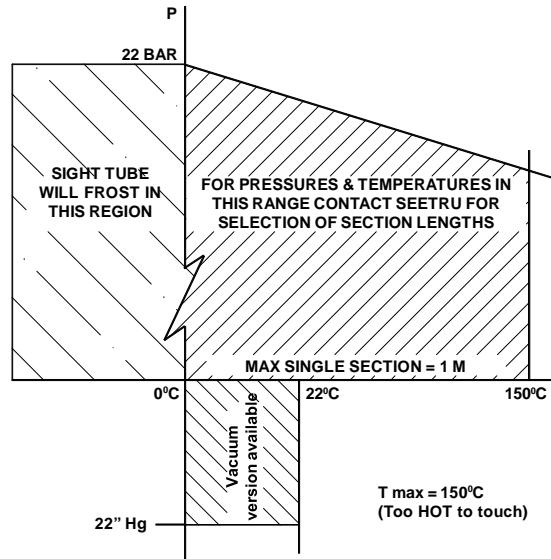

### POLYCARBONATE SIGHT TUBE

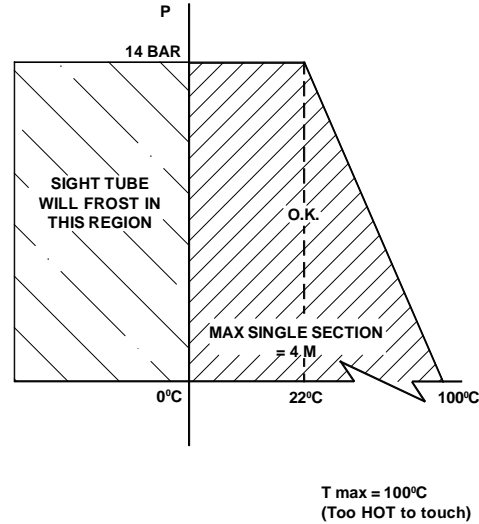

### When ordering please state:-

- Distance between gauge centres, for closed circuit, or centre to top for open circuit.
- Media identification.
- Operating temperature and pressure.
- Type of valve units, end assemblies.
- Material of construction, dependant on fluid & temperature.
- If scale plate's are required.

### EASE OF INSTALLATION & MAINTENANCE

The Quickmount liquid level gauge can be installed without the use of special tools. Threaded end Units are screwed into female tank bosses. The gauge collars slip over these Units and are secured by hand tightening retaining nuts. 'O' ring sealing is used throughout. The isolating valves will allow column removal without the need to drain the tank.

### TANK CALIBRATION

Where a measure of the precise storage volume is required, an engraved scale plate can be provided, marked with the capacity units.

### ELECTRONIC & DIGITAL READOUT

Remote reading system and/or computer interface options provide a dual system with the advantages of both electronic and sight systems. Level alarms can also be implemented.